



RIGID

PHOENIX

INSTALLATION INSTRUCTIONS



IMPORTANT

THANK YOU FOR PURCHASING RIGID INDUSTRIES' PRODUCTS FOR YOUR VEHICLE.

Please read through all these instructions and tips before proceeding with the installation. We do our best to provide a simple installation process for all applications however, a professional installation is always recommended.

Box Includes:

- Phoenix Pod Lamp (Spot)
- Wiring Deutsch Adapter
- Mounting Hardware
- Surface Mount Brackets
- Power Mode Magnet Switch



PHOENIX



INSTALLATION INSTRUCTIONS

CAUTION: Always disconnect any power sources connected to your vehicle before servicing fuses or electrical systems. Take care to avoid any heat sources and sharp or abrasive surfaces.

MOUNTING DIAGRAM

A	M8x25mm Carriage Bolt
B	M8 Flat Washer
C	M8 Lock Washer
D	M8 Hex Nut
E	M6 Nylon Lock Nut
F	M4 Nylon Lock Nut
G	Mount Bushing
H	M6 Flat Washer
I	M4 Flat Washer
J	M6x22mm Socket Head
K	M4x22mm Socket Head
L	Surface Mount Bracket

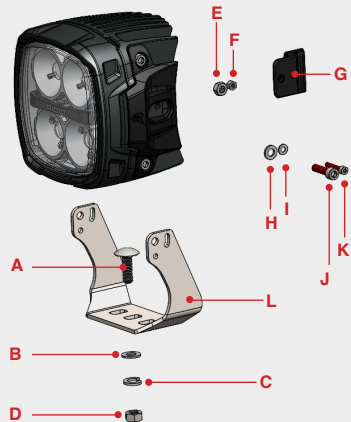

ASSEMBLY INSTRUCTIONS

STEP: 1

Place the M6 Nylon Lock Nuts into the rear of the Heatsink in the locations shown in Figure 1. Ensure that the Nylon Locking feature is oriented towards the center of the Lamp.

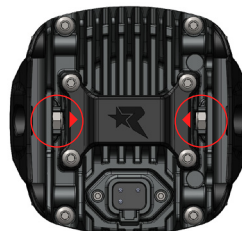

Figure. 1

STEP: 2

Place the M4 nylon lock nuts into the two plastic Mount Bushing as shown in Figure 2. Ensure that the nylon locking feature is facing outwards towards you.



Figure. 2

STEP: 3

Install the two Bushings into the rear of the Heatsink, making sure the M4 Lock Nuts stay in place in the Bushing, as shown in Figure 3. The bushings will physically snap into place when installed.



Figure. 3

STEP: 4

Install the Surface Mount Bracket via the rear of the Lamp as shown.

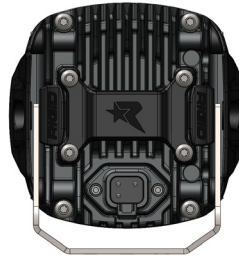
**STEP: 5**

Attach the Bracket to the Lamp by installing the M4, M6 Bolts, and Flat Washers on both sides by fitting them through the holes in the Bracket and into the Bushings and Lock Nuts.

Use the M8 Carriage Bolt, Washers, and Hex Nut to mount the assembly to the desired flat surface.

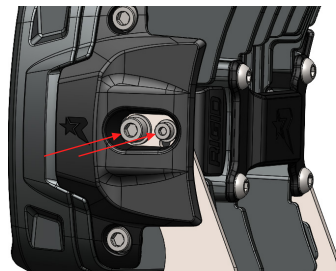

Note: If desired, the bracket can also be installed from the top if the lamp needs to be hung from an above mounting location.

MAGNETIC SWITCH

POWER CONTROL

SET YOUR POWER MODE

Included in the hardware kit is a plastic Magnetic Switch, which can be installed on the rear of the Lamp to control the power draw on the system.

The lamp is defaulted to the Low Power Setting, with the Medium and High Power modes being accessible with the use of the included Switch.

Below are the highest current draw values for each of the power modes for both the Phoenix and Phoenix XL lamps at 14V DC:



Phoenix:
Low: 3.6A
Med: 6.7A
High: 9.6A



Phoenix XL:
Low: 4.4A
Med: 9.5A
High: 13.9A

STEP: 1

To select the Medium or High power modes, Insert the switch in the rear of the heatsink in one of the two available locations:

The two locations for the magnet install are shown in the below image in red. It is suggested to use a pair of needle nose pliers to install and remove the magnet switch from either location.

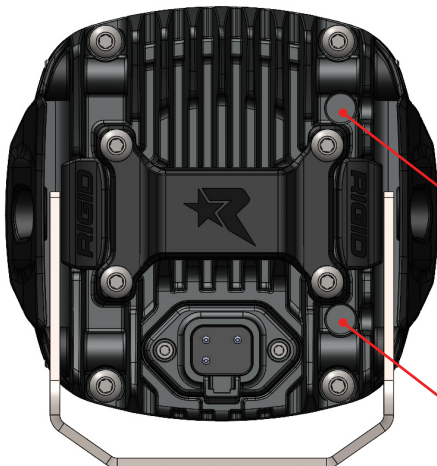

**LOW POWER
(NO MAGNET)**
PHOENIX - 3.6 A @ 14V

HIGH POWER
PHOENIX - 9.6 A @ 14V

MEDIUM POWER
PHOENIX - 6.7 A @ 14V

STEP: 2

Install the Mag Switch in your desired location. When installing the switch, ensure the bump on the switch, shown in Figure 4, is directed towards the outside of the lamp. The bump is a snap feature that fits the heatsink to ensure it stays in position.

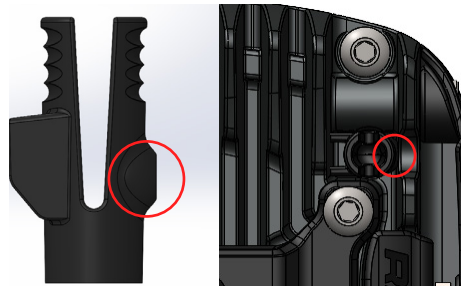

Figure. 4

When utilizing the magnetic switch to change the power, ensure that you are setting an appropriate power draw of the lamp based on the circuit that is installed on.

ELECTRICAL INSTRUCTIONS

CONNECT TO POWER

The Phoenix lamps are powered by the plug located on the rear of the lamp which includes 3 pins. Provided in the box is a wiring adapter with the pre-wired plug.

The table notates which pin and function correlates to the wire color on the wire adapter. The black wire is for ground, the red wire for main power, and the white wire is the trigger for changing the lamp's color mode and backlight.

ELECTRICAL CONNECTIONS

	RED WIRE	BLACK WIRE	WHITE WIRE
REQUIRED WIRE SIZE	10 GAUGE	10 GAUGE	12 GAUGE
CORRELATION	POWER (VIN)	GROUND (GND)	POWER (CTRL)

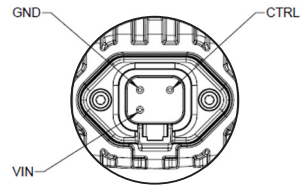

When wiring the lamp, ensure that you always connect the control wire to power. Never ground your control wire. This risks damage to electrical components.

SWITCHES

When wiring the lamp into a vehicle, it should be installed using two different switches. The main power is wired to a 2-position switch for on/off control and the control line to a momentary switch.

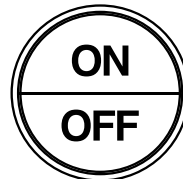

Power Switch



Mode Control

When routing wire harness through any metal surface be sure it is free of any sharp edges and protected using wire sheathing or a grommet.

COLOR MODES

There are five different main output color modes, and a backlight mode built directly into the lamp. While the lamp is powered on, quickly press and release the momentary switch (control line) to cycle to the next main output color. Continue through the color modes until the desired output color is achieved. Leave the lamp powered on in that mode for a minimum of 5 seconds to internally save that mode. The next time you power it on, it will turn on in that saved color mode.

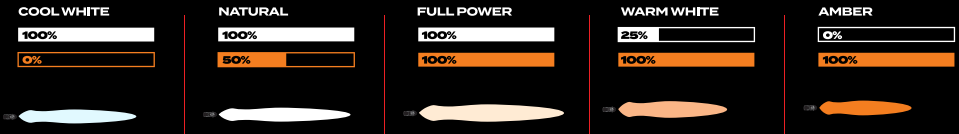

BACKLIGHT

In order to access the backlight function, press and hold the momentary switch for 5 seconds and release. The lamp will change from the main output to Amber Backlight. Leave the lamp powered on in that mode for a minimum of 5 seconds. This will trigger the lamp to internally save the mode, so the next time you power it on, it will turn on in that saved mode. When you want to return the lamp to the main output, quickly press and release the momentary switch and the lamp will return to the last main output mode prior to going into backlight mode.

FACTORY RESET

If there is ever a situation where there are multiple lamps on a single control circuit and the outputs do not match, you can press the hold the momentary switch for 10 seconds. This will trigger all the lamps on that circuit to reset to the same main output color, then you can reselect the desired output.

If connecting to an existing switch be aware of the current rating of your selected switch, if switch rating is less than the amperage required to power your lighting then a relay must be added in line to prevent failure of the switch.

If connecting to existing wiring, make sure to use appropriate fusing and wire gauge. Be sure to use heat shrink tubing on all connections to ensure a weather tight seal.

LENS REPLACEMENT INSTRUCTIONS

CHOOSE YOUR BEAM PATTERN

Alternate or replacement outer Lenses (sold separately) can be used to replace damaged Lenses or for alternate light beam patterns.

STEP: 1

Ensure the Phoenix Lamp is removed from the vehicle. Remove the Surface Mount Bracket and Mounting Hardware from the Lamp for easier access to the Bezel Bolts.

Address step 4 and 5 in the assembly instructions for details.

STEP: 2

Place the Lamp Lens side down on a clean non-abrasive surface to avoid scratches. Remove the four M6 Bezel Bolts located on the back of the Lamp.

This will release the Lens Bezel from the main body of the Lamp and allow you access to the Lens and lens Gasket.

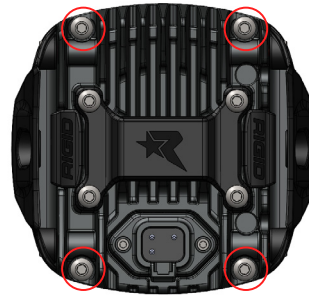

STEP: 3

Carefully remove the outer Lens and Lens Gasket from the main body.

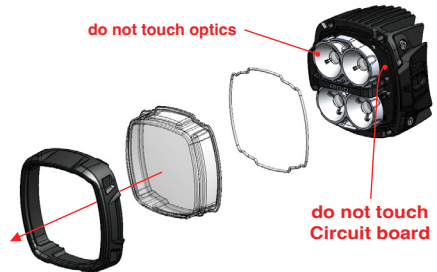

When changing the lens on the Phoenix lamp, be sure to wear gloves and do not touch the interior side of the lens causing fingerprints or other debris to be on the lens. If necessary, the inside of the lens can be cleaned by rinsing it with isopropyl alcohol.

When removing the lens, be sure not to touch the optic assembly or the PCBA (Circuit board) surfaces. Fingerprints and other debris on the optic are difficult to clean without damaging the polished surfaces. Contact with the PCBA surfaces could lead to corrosive salts and oils, which may damage electrical components.

STEP: 4

Turn the Lamp onto the Heat Sink facing upward. Place the new Lens Gasket in the Gasket Channel.



When installing the Lens, compressed air can be used to remove any debris from the inside surface of the Lens or from the Optic and main Lamp assembly. Spray in light bursts 10+ inches from the Lens surface.

STEP: 5

Place the new Lens over the top of the Gasket.

**STEP: 6**

Hold the Lens and Lens Bezel tightly to the main Lamp assembly to ensure the Lens Gasket stays in position and carefully turn the Lamp over onto its Lens. Placing it on a clean non-abrasive surface to prevent damage to the new Lens.

**STEP: 7**

Insert the Bezel Screws into the original four positions, only partially installing them to ensure they are threading into position. Then, in an 'X' pattern, fully torque the four Screws to 20in-lb. Reinstall the Surface Mount to the lamp.

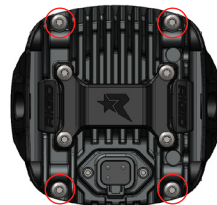

YOUR INSTALLATION IS NOW COMPLETE.

WELCOME TO

RIGID NATION



WARRANTY INFORMATION

For warranty information, visit www.rigidindustries.com/about/warranty
779 N Colorado St, Gilbert, AZ 85233 • 855-760-5337
www.rigidindustries.com

RIGID, Phoenix, Phoenix XL, and Rigid Industries are registered and/or common law marks owned by JST Performance, LLC, a Delaware limited liability company d/b/a Rigid Industries.

11-14903-A

RIGID