

FRC-4000 INSTALLATION SHEET

CUSTOMER SERVICE

PHONE: 800-206-4070, Mon - Fri 8:00 am - 5:00 pm CT

TOOLS REQUIRED

- Scissors or utility knife
- 9/16" Wrench
- 7/16" Wrench
- Tape measure

TOOLS PROVIDED

- 6mm Allen wrench

NOTE: It is important that all the areas where the bed cover mounts to the truck are clean and free of debris before installation.

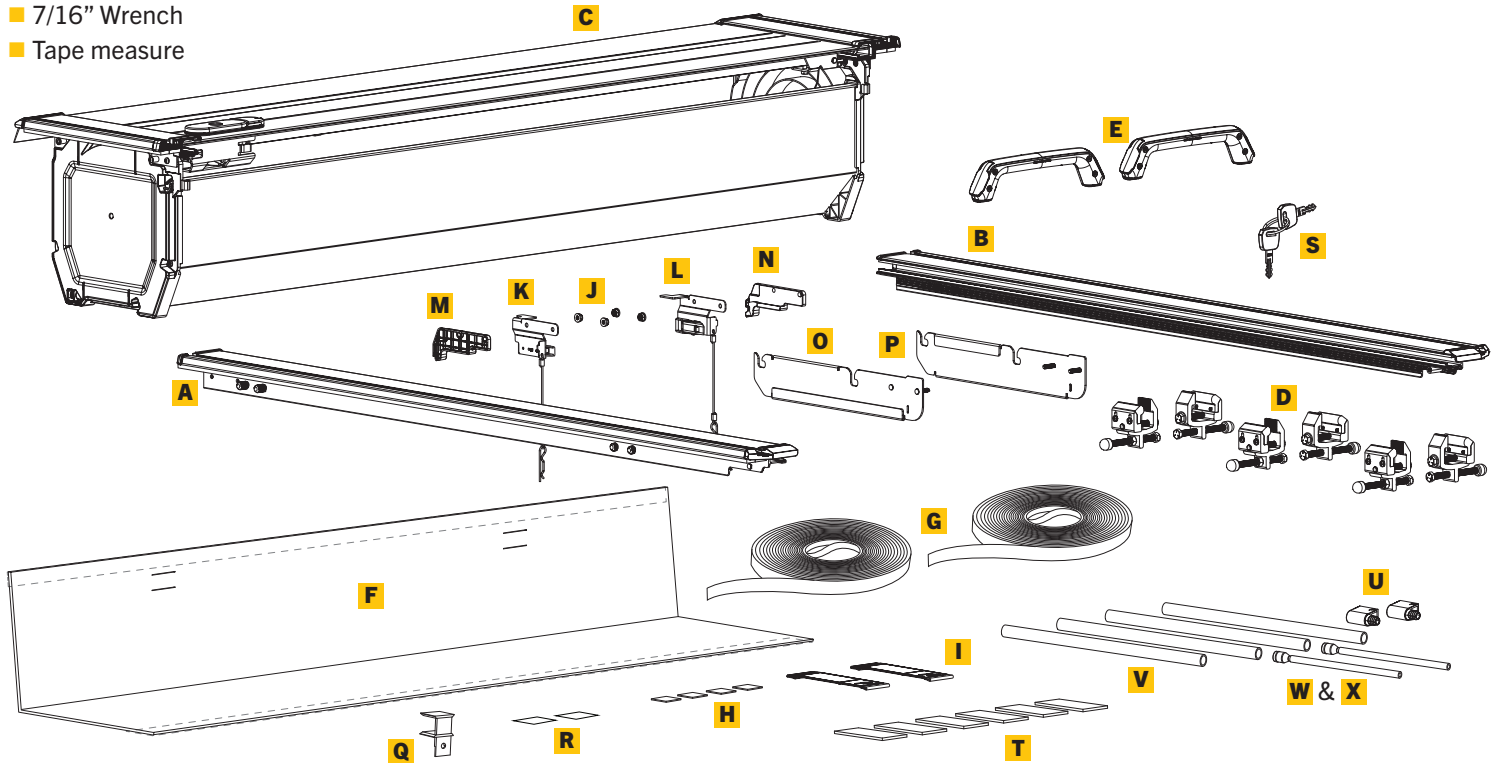

PARTS INCLUDED

- A** 1x Driver side rail
- B** 1x Passenger side rail
- C** 1x Canister assembly
- D** 6x Clamps
- E** 2x Lift handles
- F** 1x Canister protection
- G** 2x Hook and loop - long
- H** 4x Hook and loop - short
- I** 2x Straps for lift handles
- J** 4x 1/4-20 nuts
- K** 1x Driver side latch assembly
- L** 1x Passenger side latch assembly
- M** 1x Driver side rail alignment spacer
- N** 1x Passenger side rail alignment spacer
- O** 1x Driver side rail mounting bracket
- P** 1x Passenger side rail mounting bracket
- Q** 1x Shipping bracket
- R** 2x Adhesion promoter packets
- S** 2x Keys
- T** 6x Shims
- U** 2x Drain tube disconnects
- V** 4x Large drain tubes (No connector)
- W** 2x Small drain tubes with adapter (X) attached

IMPORTANT: Extra parts provided (not needed for this install)
Bag labeled: F09-1013. Includes: 4 Phillips screws,
2 Allen head screws and a Allen wrench.

NOTE: The screwpack can be discarded.

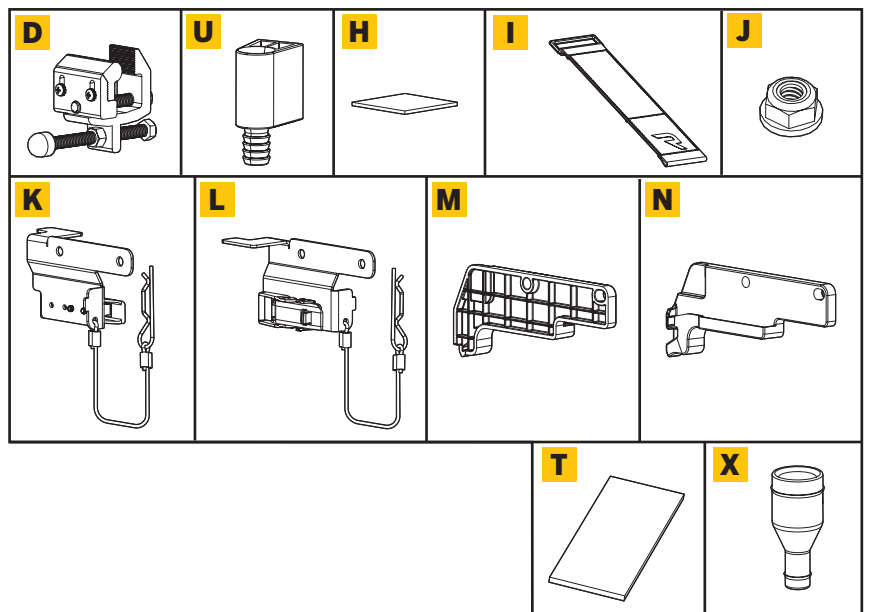
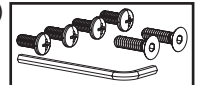

IMPORTANT

READ BEFORE YOU BEGIN INSTALLATION

IT IS CRITICAL FOR YOUR SAFETY THAT YOU CAREFULLY READ AND FOLLOW THE SAFETY CAUTIONS AND INSTALLATION INSTRUCTIONS BOTH PRIOR TO AND DURING INSTALLATION.

USER SAFETY CAUTION

During installation, be mindful of the potential for sharp edges on the product or vehicle. Taking proper safety precautions helps ensure a safe and smooth installation process.

Always wear protective gloves and handle components with care to reduce the risk of injury.



TEMPERATURE SURFACE CAUTION

During high temperatures or extended sun exposure, surfaces of this product may become hot to the touch, posing a risk of burns or injury. Use caution when handling the product in hot weather and allow time for it to cool before contact.

Always check surface temperature before use to ensure safe handling conditions.



FASTENER TORQUE CAUTION

All fasteners must be tightened to the specified torque values provided in the installation instructions to ensure proper fit and safe operation of the tonneau cover. Under- or over-tightening can lead to product failure, potential damage to your vehicle, injury, or safety hazards while driving.

Always use a calibrated torque wrench and follow the specifications in the installation instructions.



PINCH POINT SAFETY CAUTION

This tonneau cover may create pinch points when closing or operating near solid surfaces such as the truck bed rails or tailgate. To prevent injury, keep hands, fingers, and other body parts clear of moving parts during operation.

Always operate the cover slowly and with caution to ensure safe and proper use.

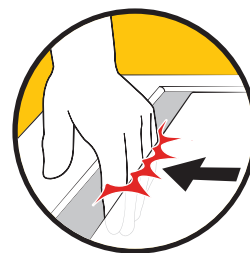

ENTRAPMENT SAFETY WARNING

This tonneau cover does not feature a manual release mechanism from inside the truck bed. To prevent the risk of entrapment, never allow anyone to be inside the bed of the truck when the cover is closed.

Always ensure the area is clear before closing the cover, and keep the cover securely latched when not in use to avoid accidental closure.



1 Rail assembly: The mounting bracket assembly (O or P). Use the supplied hardware components (J, L, N & P) and install them on the passenger side rail (B). Slip the passenger side rail alignment spacer (N) on to the studs of the passenger side rail mounting bracket (P). Then insert the studs of the mounting bracket into the holes of the passenger side rail (B). Slide the passenger side rail draw latch assembly (L) on to the studs and tighten them down with two 1/4-20 nuts (J) using a 7/16" wrench. Repeat on the driver side rail (A), using plastic spacer (M), driver side rail mounting bracket (O), driver side draw latch assembly (K) and two 1/4-20 nuts (J).

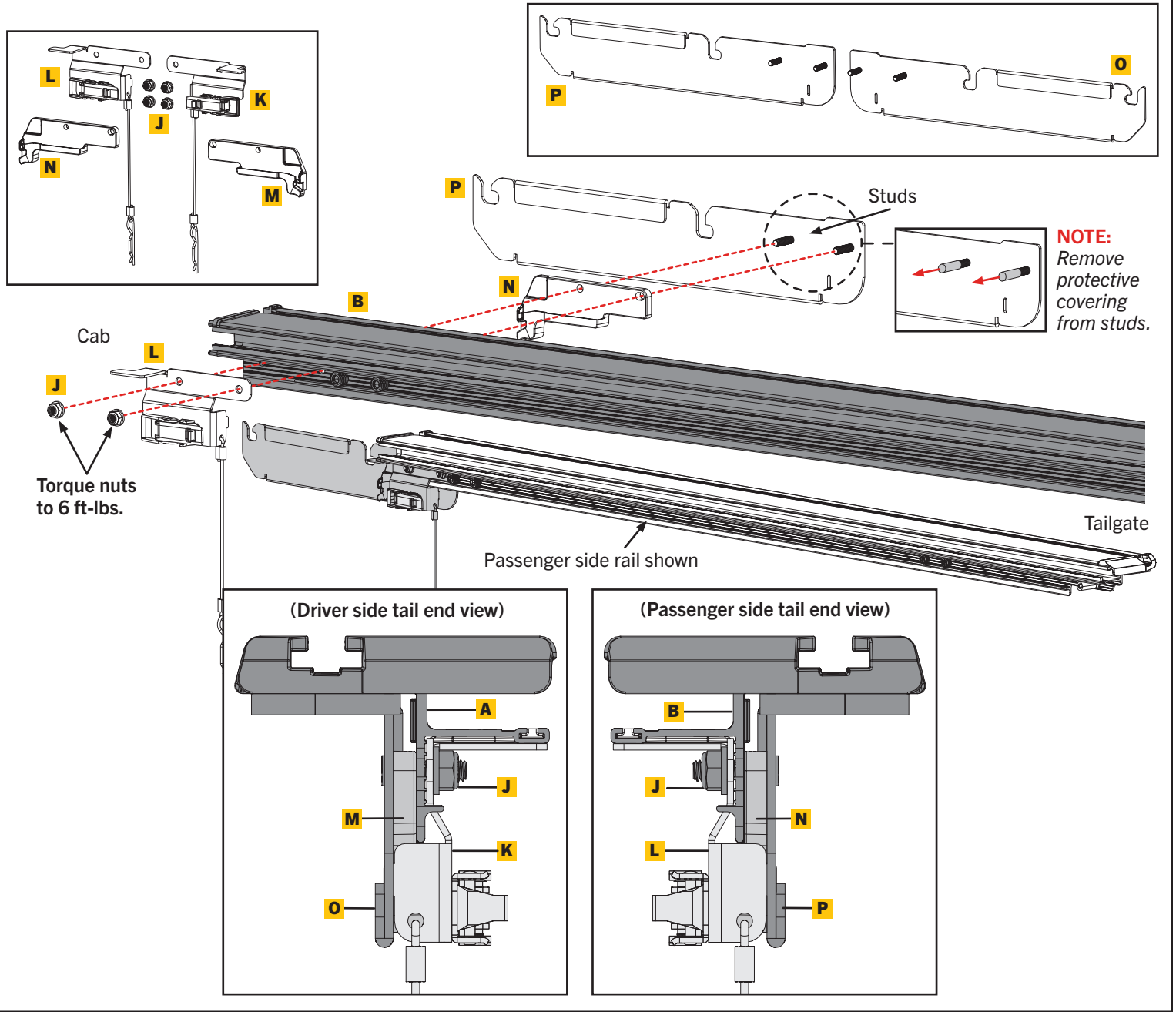

Needed for canister assembly: Canister assembly (C), 2-Large drain tubes (No connector) (V), 2-Lift handles (E), Canister protection (F), 2-Hook and loop - long (G), 2-Straps for lift handles (I) and Adhesion promoter packets (R).

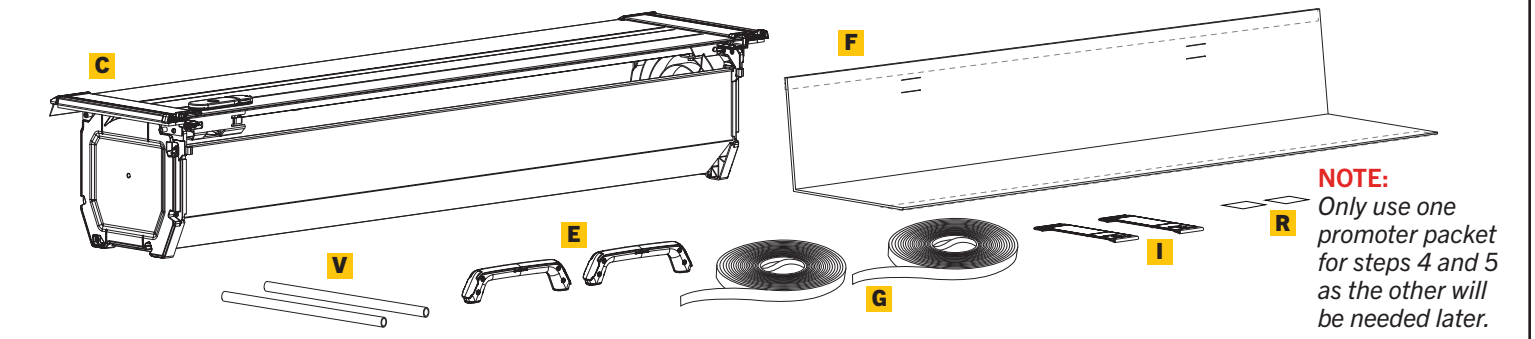

2 Canister preparation - strap installation: Insert the straps (I) in the slits in the canister protection material (F) in both places with the logo facing out.

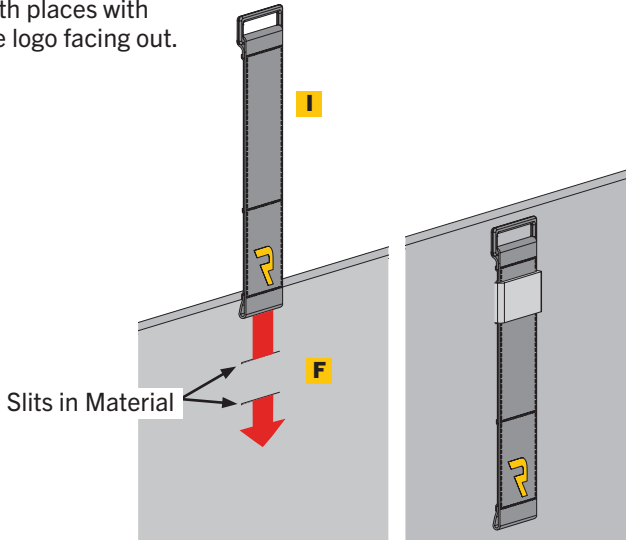

3 Canister preparation - applying hook and loop: Use two pieces of the long hook material (G) to match the length of the long loop pieces that are already sewn to the top and bottom on the backside of the canister protection material (F). Then stick each piece to the loop pieces that are already there to attach the protection piece to the canister in a later step. Leave the adhesive on both hook pieces.

NOTE: Cut hook material to length where needed.

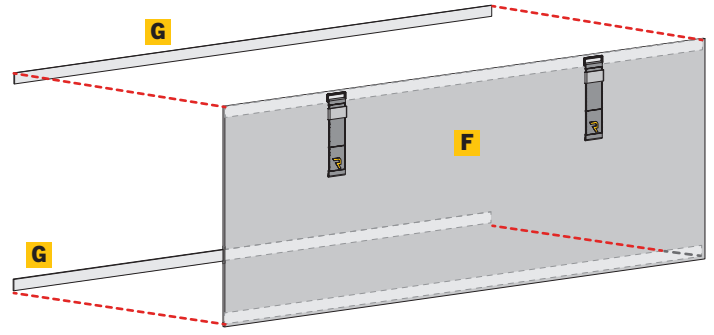

4 Canister preparation - attaching hook and loop to canister:
NOTE: Remove the plastic protective film from the canister.

Clean the canister assembly (C) where you will be applying the hook piece (G) with adhesion promoter (R). Allow the surface to dry. Before removing the backing from the hook piece, dry fit to make sure you are attaching along the top edge of the canister sheet metal by centering the protection material (F) to the space available on canister (C). Use a tape measure to help. Then while holding in place, lift and peel the backing off the hook piece and stick it to the canister. Make sure straps (I) are in the orientation shown.

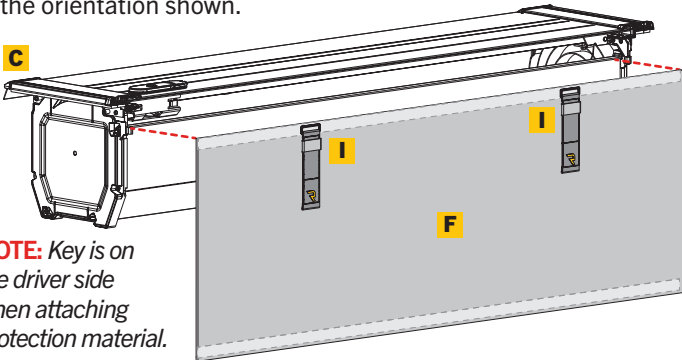

NOTE: Key is on the driver side when attaching protection material.

5 Canister preparation - attaching hook and loop to canister:

Clean the back of the canister assembly (C) where you will be applying the hook piece (G) with adhesion promoter (R). Allow the surface to dry. Pull the protection material (F) with the hook piece already attached to the bottom loop piece, wrap it around the bottom of the canister to the lower back edge of the canister sheet metal. Make sure it is pulled tight before attaching the adhesive to the canister. Then while holding in place, lift and peel the backing off the hook piece and stick it to the canister.

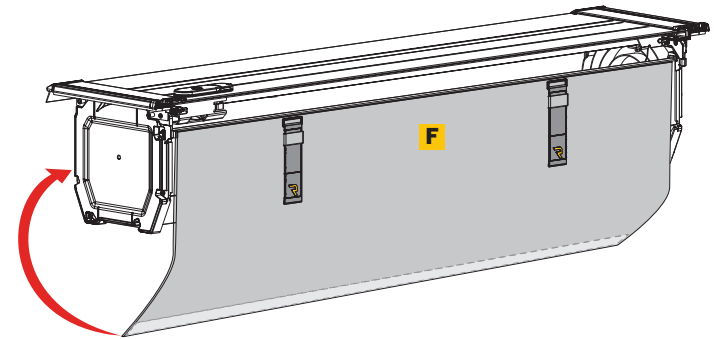

Canister preparation - canister is now protected:

Front

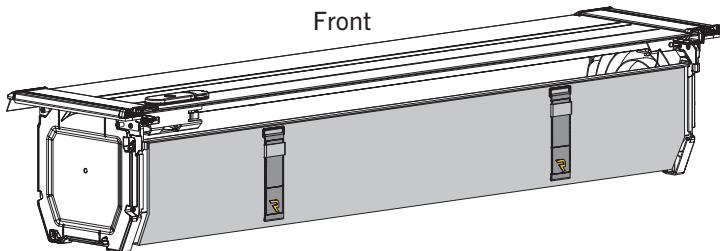

Back

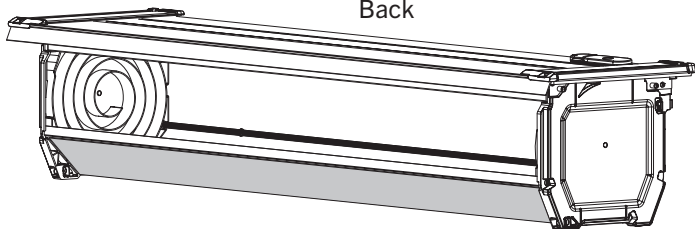

6 Drain tube installation: Insert large drain tube (V) on each spiral end barb on the bottom back side of the canister on each side. Ensure that the hose is pressed on all the way to the base. Install on both driver and passenger sides.

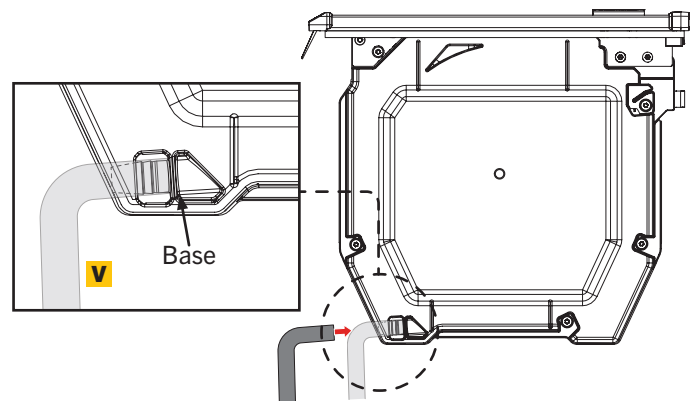

7 Installing lift handles in canister:

7a - Insert the lift handle slugs (E) into the slot on the canister rails by lifting the locking lever on each side of the handle and sliding into the slot and centering in the rail section visually. Install on both driver and passenger sides.

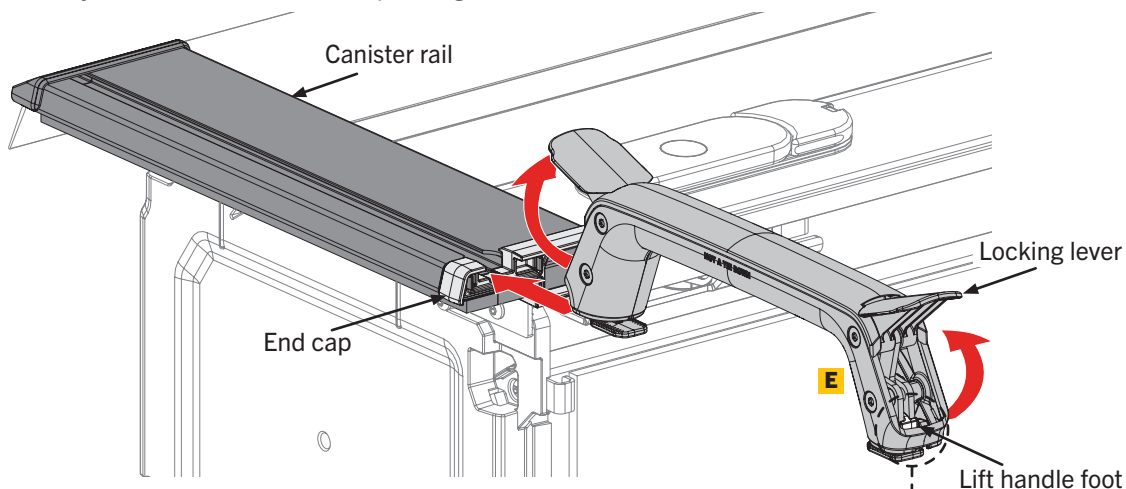
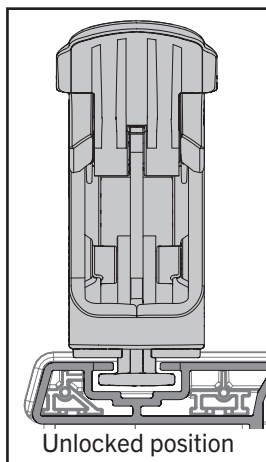

7b - When the second side of the lift handle is inserted into the canister rail, press forward and down on lift handle foot.

7c - Gently push lift handle over end cap and into the canister rail

7d - Wiggle lift handle if needed until it is past the end cap.

NOTE: Do not force it over the end cap if it gets stuck.

7e - Locking lever can be rotated down to secure lift handle to the rail once the second side of the lift handle is past the end cap.

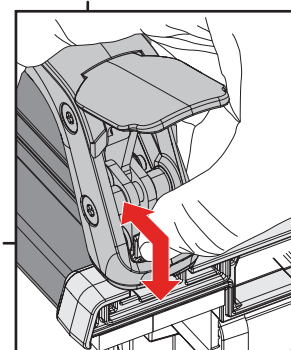
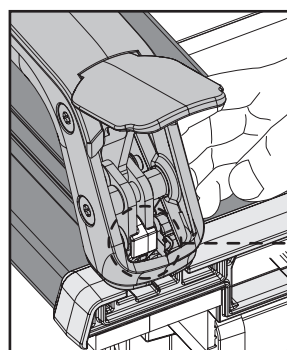

8 **Securing lift handles to the canister:** After visually centering the handle slugs (E) into the slot on the canister rails, push down on the locking lever on each side of the handle to lock in place. Now you can install the canister into the cover rails installed in steps 10-16. Install on both driver and passenger sides.

NOTE: These handles are only to be used as a lifting device for the canister. They are not to be used as tie-downs.

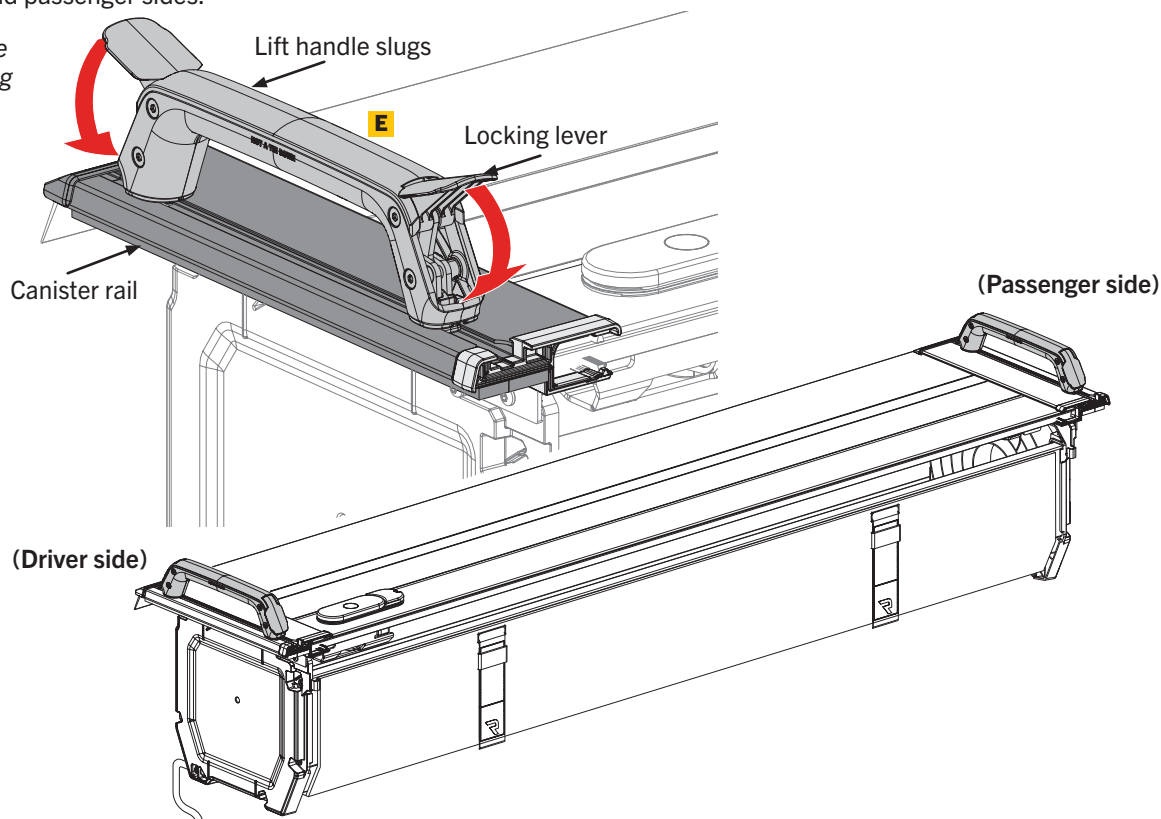
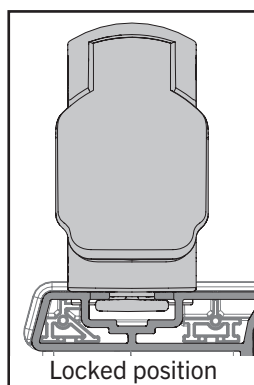

9 Prepare the bed for cover installation: **NOTE:** Prior to installing the cover, some drop-in style bed liners may need to be notched in the front/cab end corners to provide clearance for the cover canister.

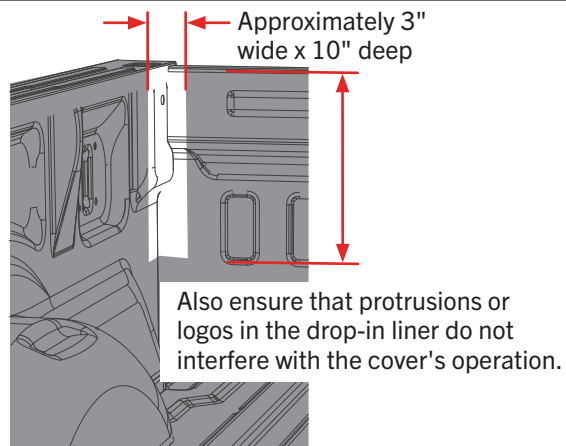

Needed for rail installation: Use the supplied hardware components (D) and (S) to install the passenger side rail (B) and driver side rail (A) to truck bed rails.

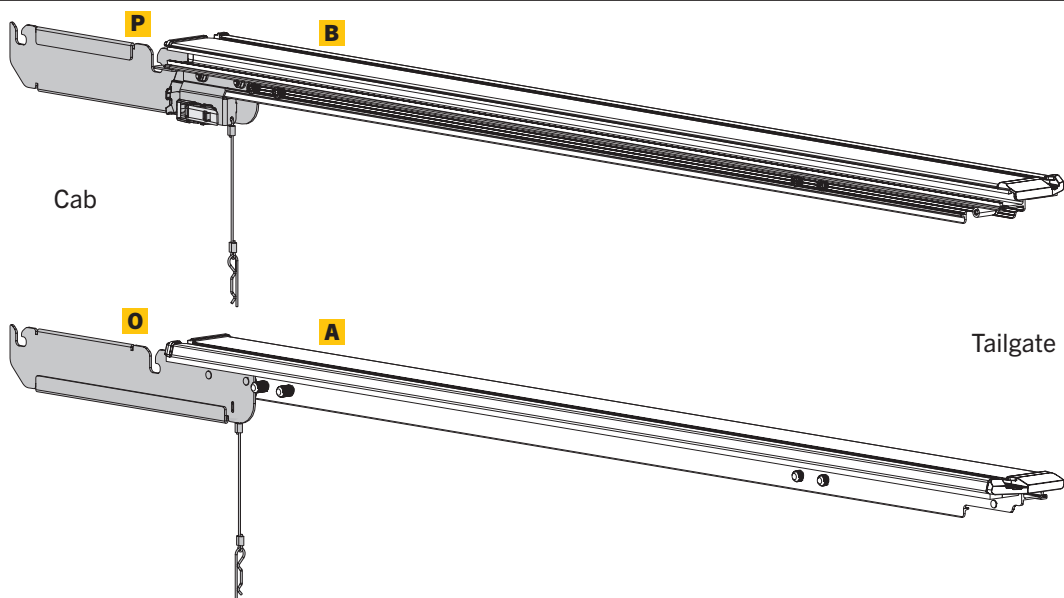
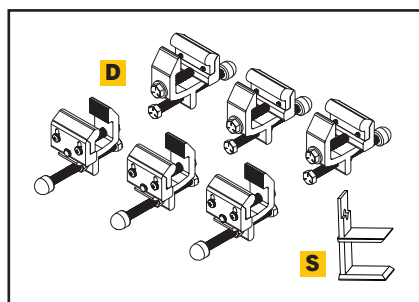

10 Rail placement on truck: Place passenger side rail (B) on to truck bed rail caps using three clamps (D) and following steps 11-16.

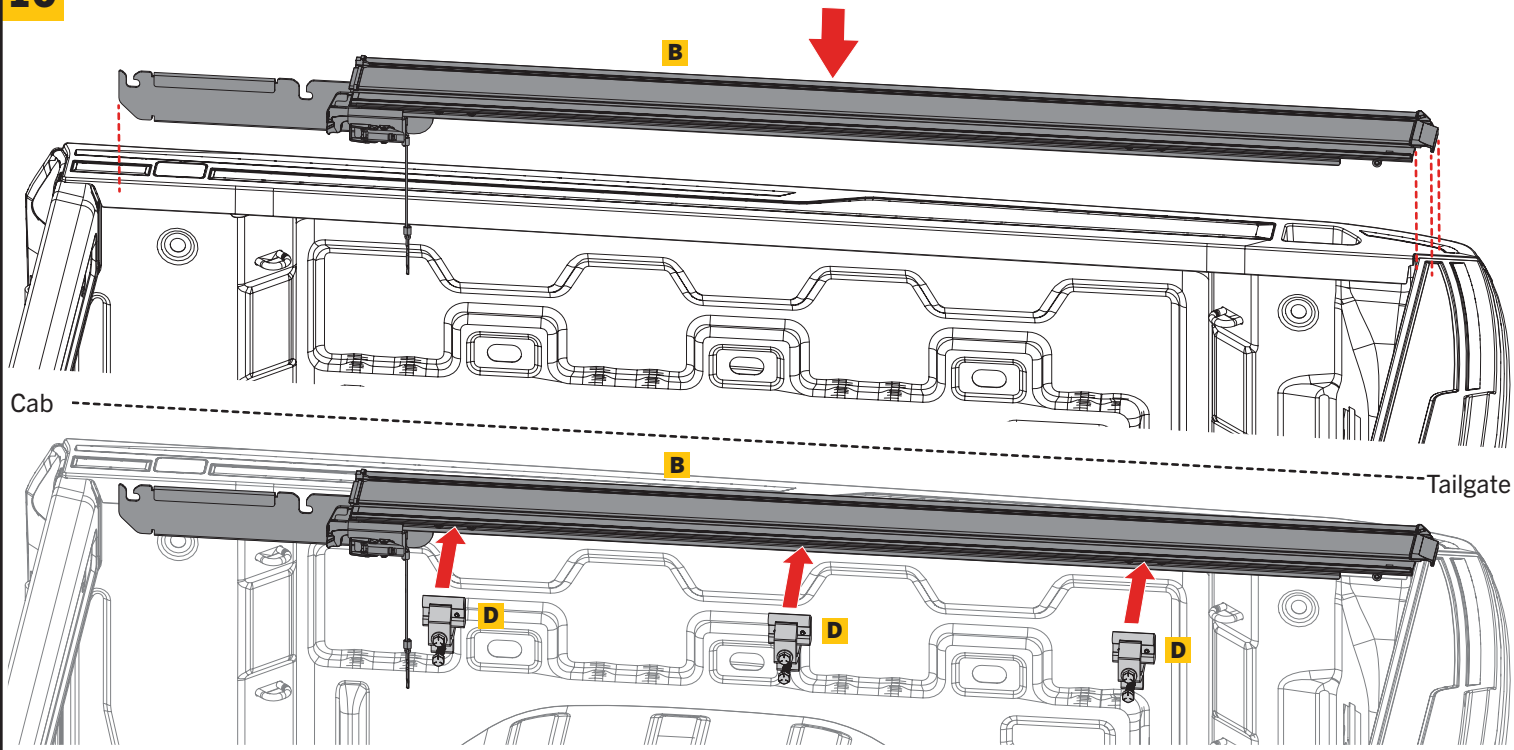

11 Position the rails: Move the rail back toward the tailgate and use the shipping bracket (Q) as a spacer to position both rails to be 1/8" from the tailgate.

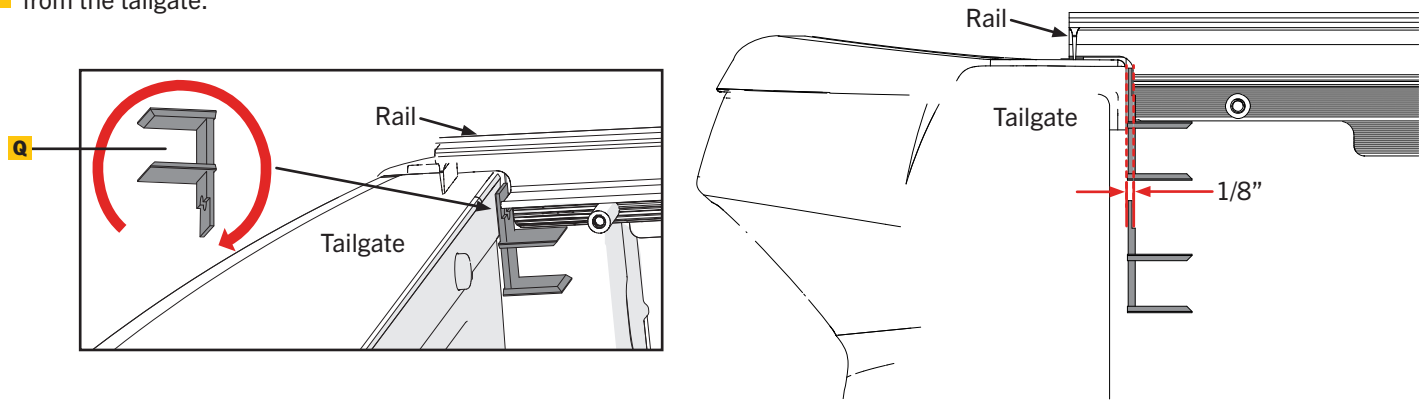

12 Insert rubber shims: Insert a rubber shim (T) between the truck plastic bed cap and the truck metal rail at each clamping location behind the adjustment screws as shown below.

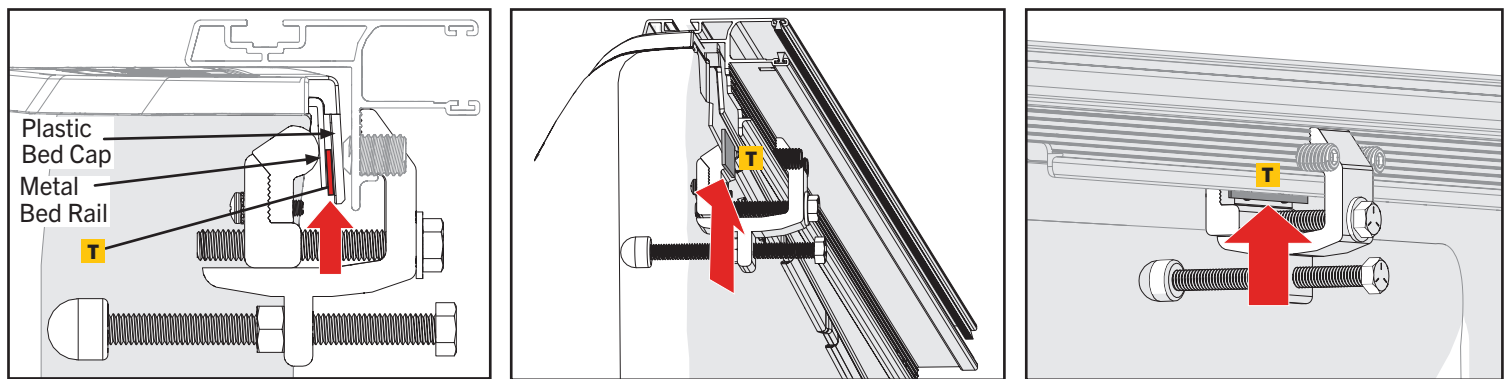

13 Install the front and rear clamps:

13a - Position the clamps (D) between the adjustment screws. Using a 9/16" or 1/2" wrench (depending on your clamps), tighten the clamps (D). It is important to push down on the rail (A & B) while tightening.

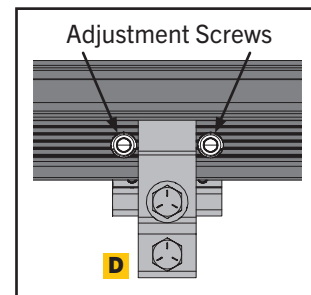

13b - The adjustable-back clamp is designed and tested for the extra loads for the retractable cover. The adjustable-back clamps must be positioned correctly under the truck bed rail to properly carry the extra loads.

13c - The adjustable top jaw of the clamp must be tucked firmly to the top and inside corner of the sheet metal of the truck bed rail.

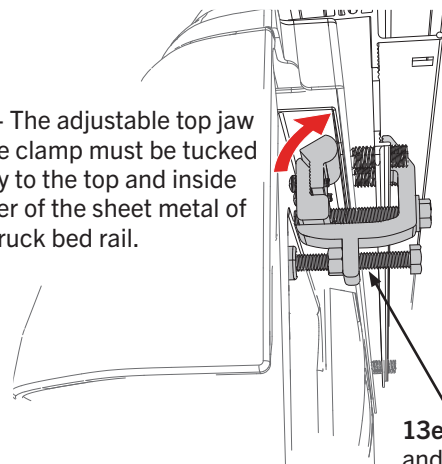

13d - If the jaw does not contact firmly into the corner of the bed flange, remove the clamp and loosen the screws to adjust the jaw.

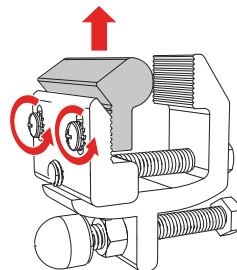

Re-tighten screws and fully engage the lock washers. Always make sure the two sets of teeth are fully engaged.

13e - Replace the clamp between the adjustment screws and recheck to make sure the jaw seats firmly into the corner of the truck bed rail.

13 Install the front and rear clamps continued:

Using a 9/16" wrench, tighten the clamps. It is important to push down on the rail while tightening. **NOTE:** Revisit this step after the canister is installed to verify both canister rails and fixed rails are flush.



NOTE: Final torque will be done at a later step.

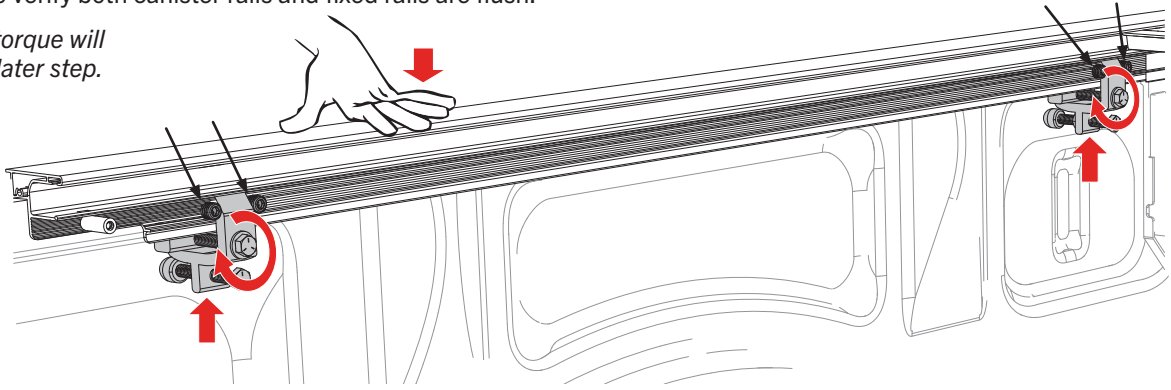

13f - Tighten the rail clamp stand-off bolt: From steps 14-16 the rails are now adjusted to be even. Loosen the jam nut, then tighten the stand-off bolt until the bumper firmly contacts the truck bed wall. Re-tighten the jam nut. **Do Not over torque the bolt.**

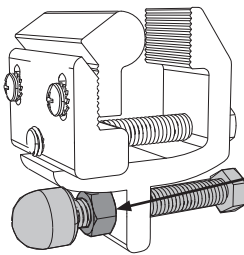

Jam Nut

NOTE: If the clamps need to be removed after the stand-off bolts are set, the jam nut and bolt will have to be loosened.

NOTE: Ensure the rails are parallel. If the rails are leaning down, have one person stand on the outside of the bed and slightly roll the rails upward while another person slowly snugs the clamps up. If the clamps are tightened too quickly or overtightened, it will cause the rails to lean down.



Due to variations in vehicle designs, the clamps may fit differently on your truck than on our test vehicles. RealTruck is not responsible for cover-to-vehicle installations, nor is RealTruck liable for any damages resulting from improper attachment, installation or use.

14 Measure the canister: Measure the distance C on the canister with a tape measure.

The measurement on the canister rails should match A & B measurements.

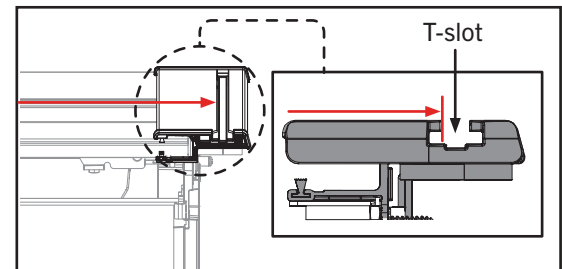
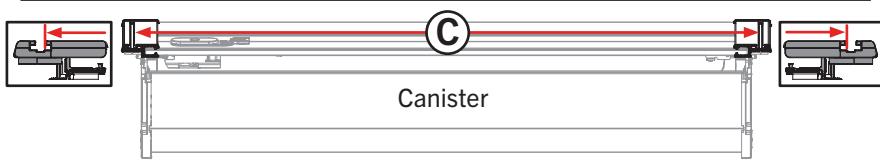

15 Measure and record the distance between the rails:

15a - Measure A & B and adjust the white adjustment screws (step 16) using the provided 6mm Allen wrench until both rails are equal with the canister rails measurement (C).

15b - They must measure within $\pm 1/16"$ before inserting the canister.

15c - Refer to step 16 if adjustments are needed.

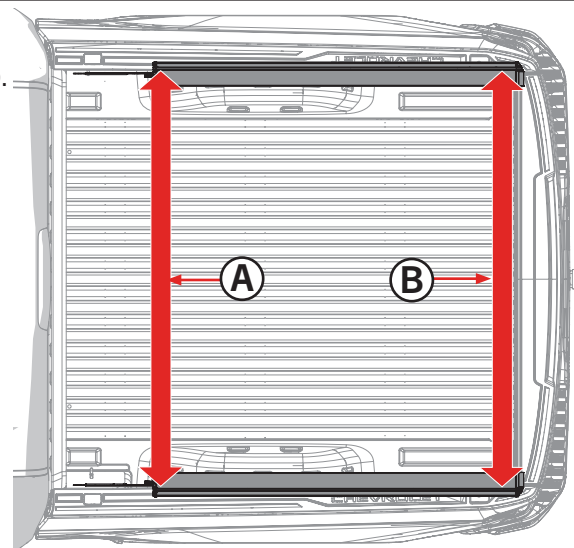
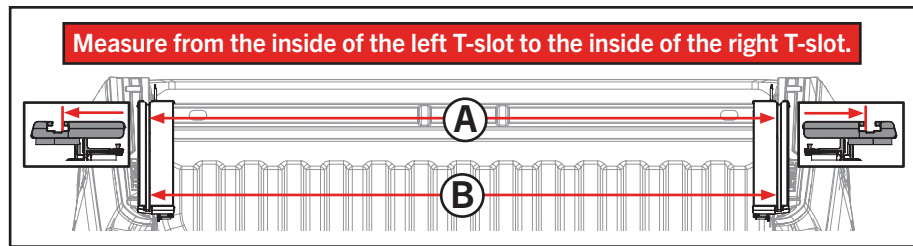

16 Adjust the distance between the rails: If A & B do not equal C in step 14, adjustments are needed using the following step. Remove the clamps and turn the white adjustment screws with the 6mm Allen wrench to move the rails. One complete turn = $1/16"$. Turn both screws. **NOTE:** When properly adjusted, replace the clamps as in steps 13. Make sure the clamps are tight.

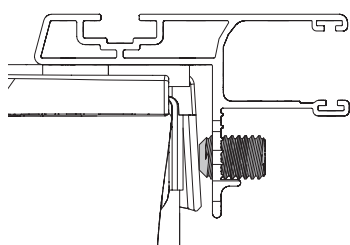

If the rails measured too close together, turn the screws counter clockwise.

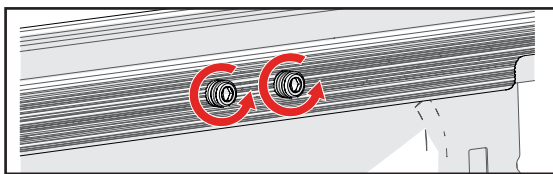

If the rails measured too far apart, turn the screws clockwise.

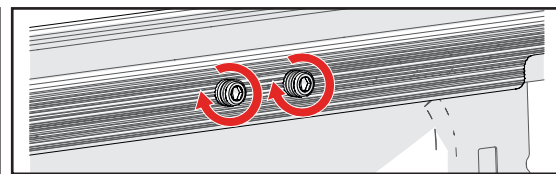

17 Installing canister to the rails: IMPORTANT: This installation recommends two people for lifting and assembly. Make sure the cover is rolled up into the canister and the latch is closed. With two people lift the canister assembly (C) by the lift handles and set the canister on to the bed of truck. Then the two people climb into the truck bed. Then lift the canister to set the canister into the mounting bracket boot retainer feature equally on each side shown below on both driver and passenger sides.

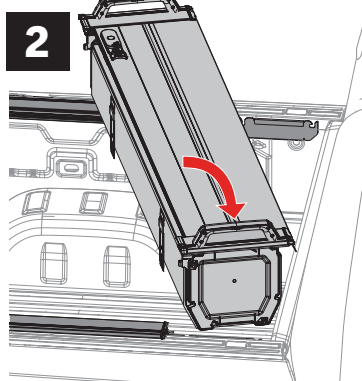
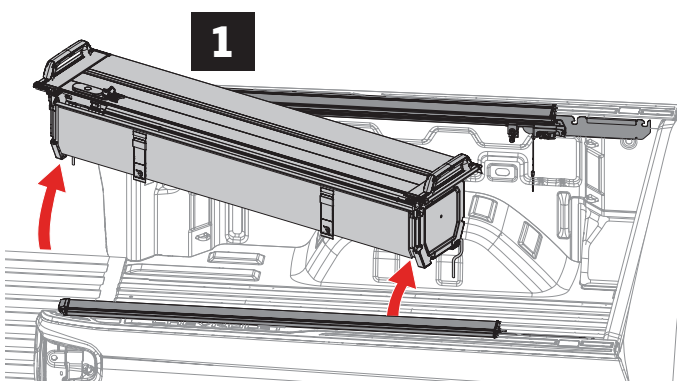

NOTE: Installing the canister **WITH CARE** and **SQUARELY** will prevent damage.

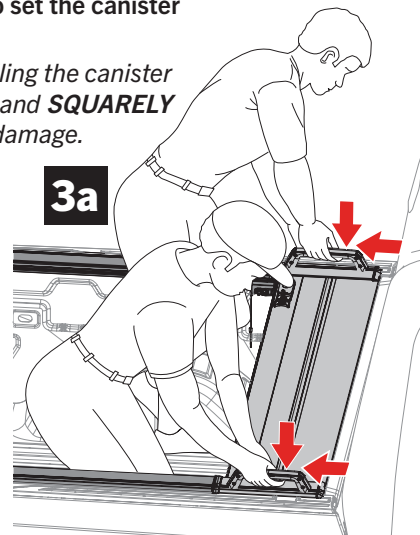

NOTE: Make sure the canister is fully inserted and seated on the bed caps.

NOTE: Engage the canister into the mounting bracket boot retainer feature by pulling the canister toward you.

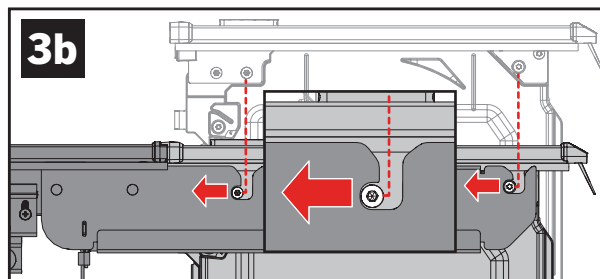

18 Draw latch operation - securing cover to rails: Depress spring tab on the driver side draw latch assembly (K) and open draw latch, rotate draw latch around the catch bracket and press on draw latch until spring tab is engaged. **NOTE:** Ensure there is **NO** visible gap or misalignment in rail end caps on both the rails and canister rails. Revisit step 16 if adjustments are needed. **IMPORTANT:** Make sure draw latch is secured with the provided pin. Check alignment with the fixed rails and adjust clamps accordingly.

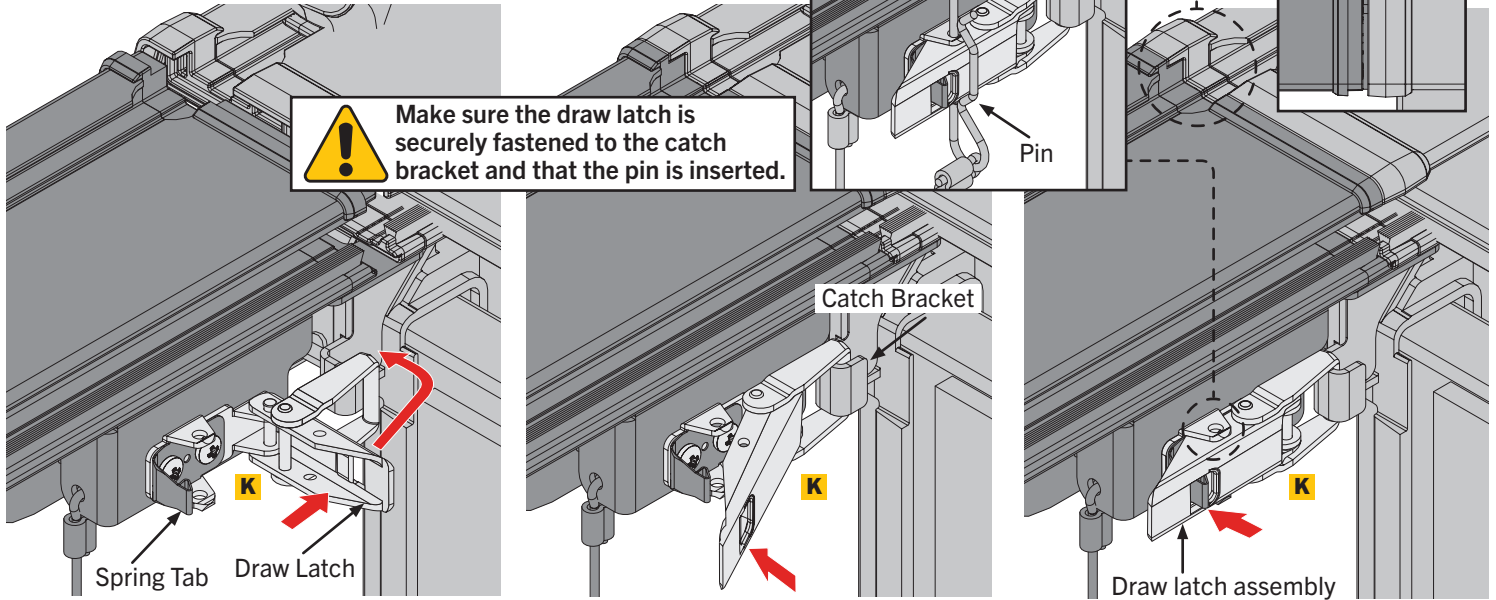

! Make sure the draw latch is securely fastened to the catch bracket and that the pin is inserted.

NOTE: Make sure the fixed rails are flush with the canister rails.

19 Canister should be sitting on bed caps: Make sure the canister assembly (C) is fully inserted and seated on the bed caps on driver and passenger sides.

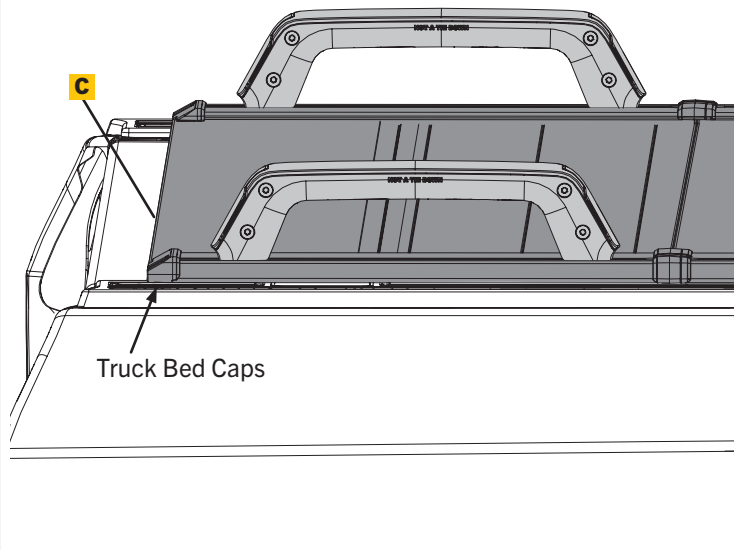

20 Proper flap seal on top of bulkhead: Make sure the flap seal is sitting flat on the bulkhead and that it is to length so it falls within the bed caps. Some trimming may be necessary.

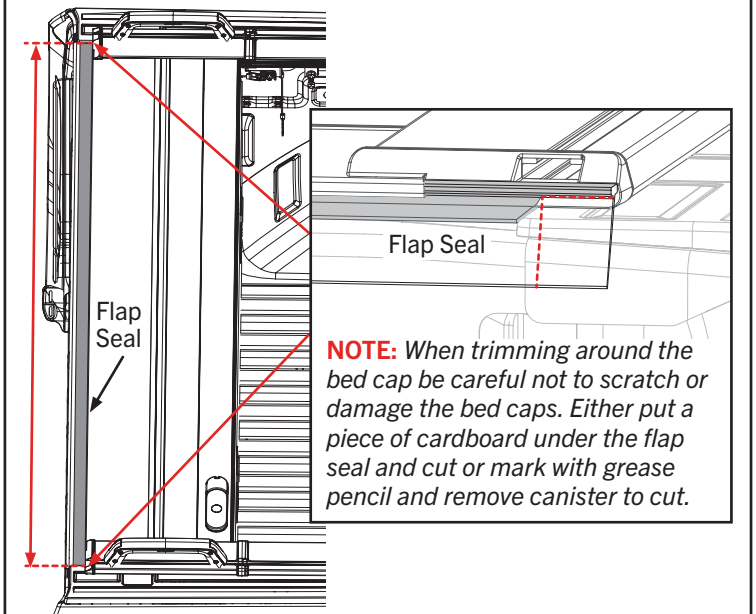

NOTE: When trimming around the bed cap be careful not to scratch or damage the bed caps. Either put a piece of cardboard under the flap seal and cut or mark with grease pencil and remove canister to cut.

21 Check for proper fit between the front cover and the rolling cover: See cover use section to see how to unlock and close cover if needed. With the cover closed and latched, if there is less weatherstrip exposed on one side versus the other then adjust that rail more forward and toward the cab. Loosen the clamps and move the rail. Check again for equal spacing, adjust as necessary then tighten all the clamps per step 13.

NOTE: Make sure the distance is the same.

! Torque all clamps at this time and make sure all fasteners are tightened.

⌚ Tighten the clamp bolts and jam nuts to: 6.7 ft-lbf, 9,1 N-m

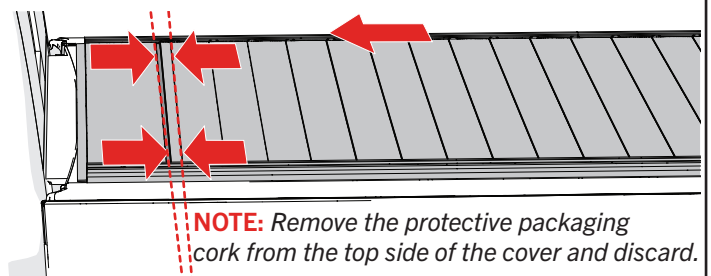

NOTE: Remove the protective packaging cork from the top side of the cover and discard.

Needed for drain tube disconnect assembly: 2-Large drain tubes (No connector) (V), Drain tube disconnect (U), 4-Short hook and loop pieces (H) with adhesion promoter (R).



22 Assembling drain tube disconnect to bed of truck: Clean the flat area on the drain tube disconnect (U) where the short hook and loop piece (H) with adhesion promoter (R). Allow surface to dry.

22a - Figure out which method A (Truck bed with drop-in or spray-in bed liner or no bed liner) which uses two pieces of hook and loop (H) or B (Truck bed with carpet) which uses one piece of hook and loop (H) to connect the drain tube disconnect (U) to the inside front of the bulkhead of your truck bed. Peel the backing off and position the hook and loop to the back of the drain disconnect (U). Apply pressure to the entire seal to make sure the adhesion is good. This way it is already attached no matter which way you have to install the drain tube disconnect.

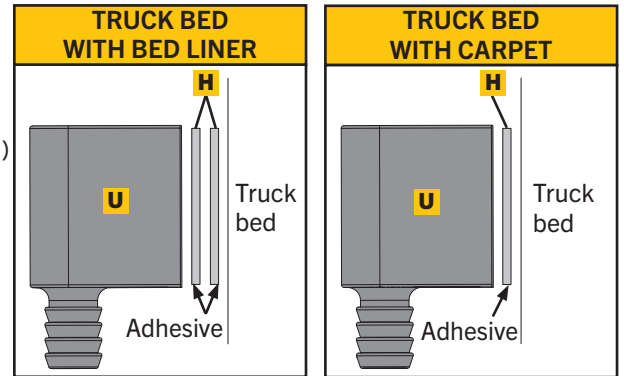

22b - Insert the loose end of the second drain hose into the hole of the truck bed floor before attaching the tube disconnect (U) to the truck to make sure you have enough hose length to allow the water to exit the bed (location varies per truck). Then see if the drain tube disconnect reaches to where you want to attach it. **NOTE:** You may need to cut the desired length of each drain hose to prevent kinks in the drain hoses.

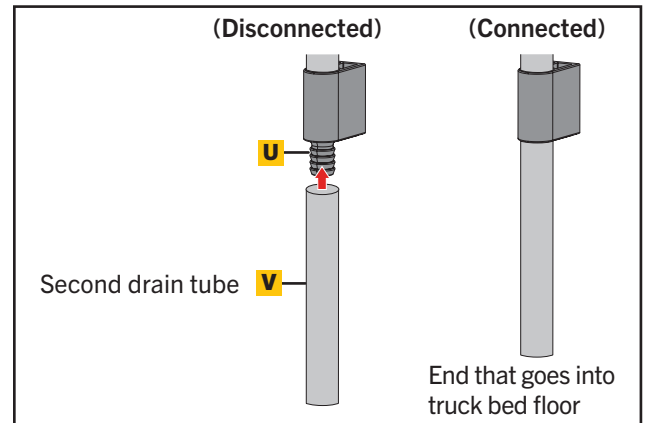

23 Installing drain tube disconnect to bed of truck:

23a - Attach the bottom end of the first drain tube (V) that you connected to the canister in step 6 to the open end of the top part of the drain tube disconnect (U) as shown.

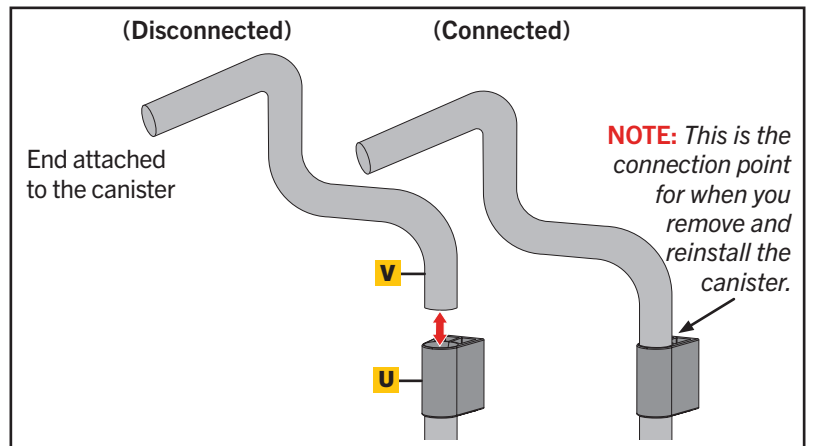

23b - Make sure the hoses and disconnect are running vertical, no kinks. Once you have the right length of both hoses and you find the right location that will be accessible under the canister, attach the drain tube disconnect to the truck using method A or B on driver and passenger sides. The drain tube disconnect allows you to remove the canister easily.

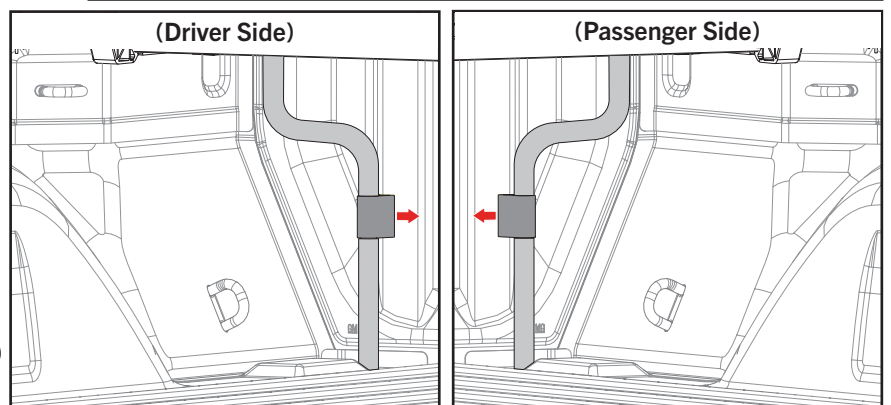

NOTE: Use small drain tubes with adapter attached (W & X) as needed for some truck beds with smaller drain holes.

24 Lift handle storage: Store the lift handles (E) in straps (I) that are attached to canister protection (F). **NOTE:** When lift handles are not in use for lifting canister in place, store them in this position.

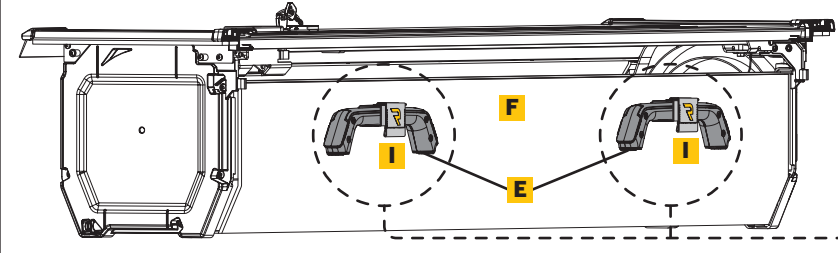

DIRECTION OF STRAP

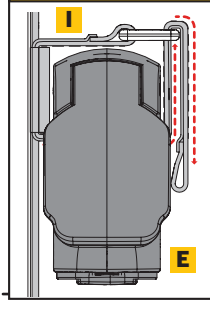

IMPORTANT: Do not drive with lift handles attached to the rails.

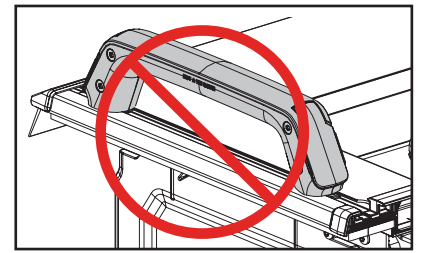

You have successfully installed your removable canister.

COVER USE

DETACHING THE CANISTER: Insert the lift handles (E) into the opening in the rails, visually centering them and pushing down on the locking lever on each side of the lift handle (E) to lock in place. Pull safety pin then depress the spring tab and open the draw latch, rotate draw latch from around the catch bracket to disengage. Now you can remove the canister assembly (C) from the rails. Repeat on passenger side.

Locking lever

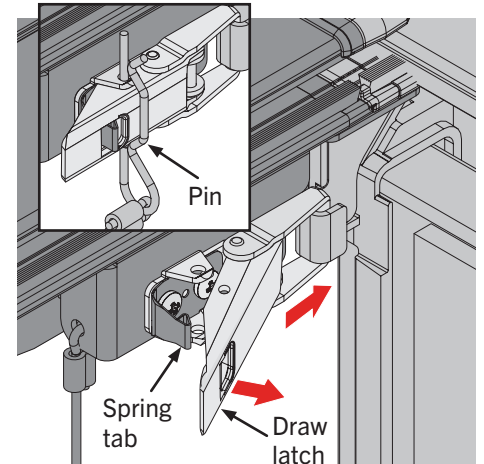
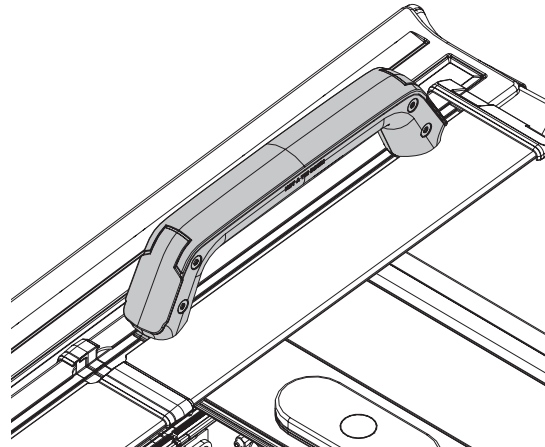
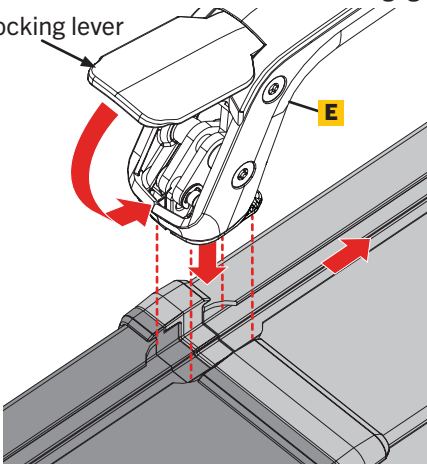

REMOVING CANISTER FROM THE RAILS: IMPORTANT: This installation recommends two people for lifting and assembly. Make sure the cover is rolled up into the canister and the latch is closed. With two people using the lift handles (E), lift the canister assembly (C) out of the mounting bracket boot retainer feature first as shown below on both driver and passenger sides on to the bed of truck.

NOTE: Disengage the canister from the mounting bracket boot retainer feature by pushing the canister toward the cab.

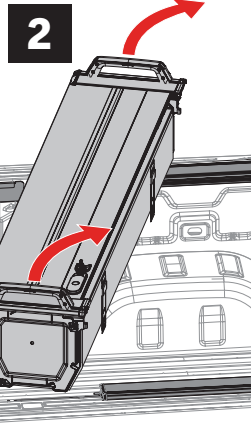
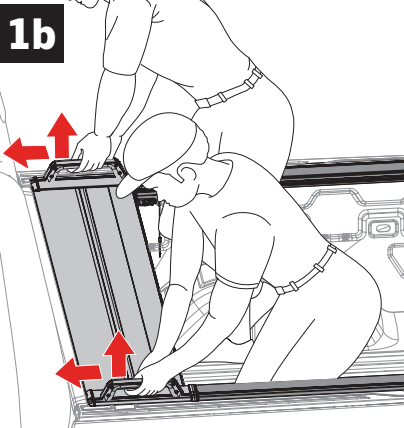
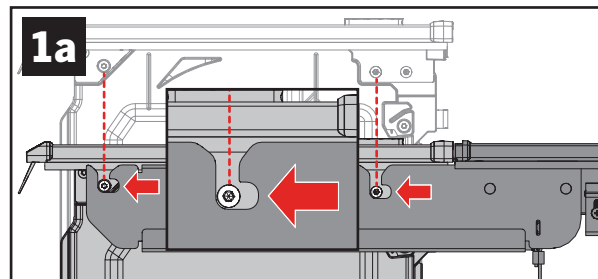

3 NOTE: Ensure that the drain tubes that are attached to the canister disconnect piece are removed before removing the canister from the bed.

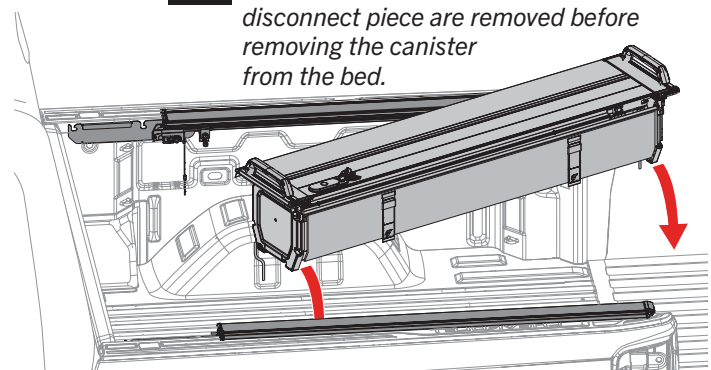

OPENING AND USING THE COVER: To use your cover, open the lock cover, insert key and turn until unlocked. Then press the button on the pop-up latch to release. The latch handle can be used to push the cover closed or pull the cover open.

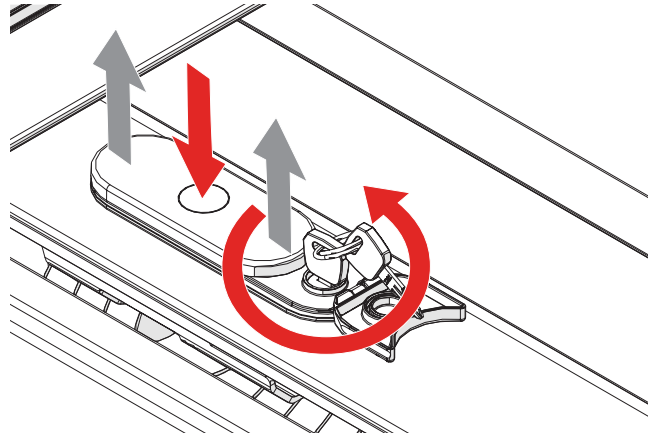
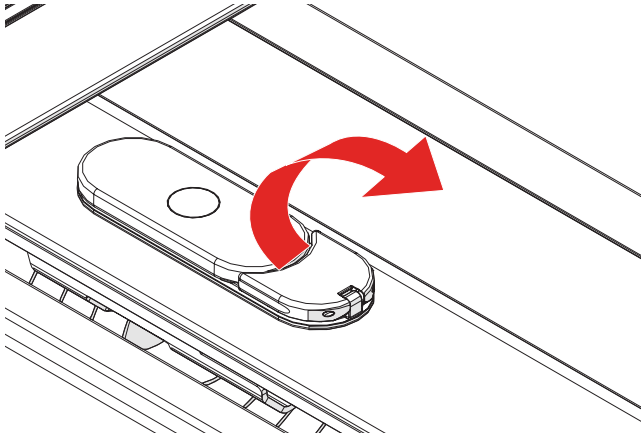

CLOSING AND LOCKING THE COVER: To latch your cover anywhere along the rail, push down firmly on the pop up latch. You can lock this location by opening the lock cover, inserting the key and turning it to lock the cover in place.

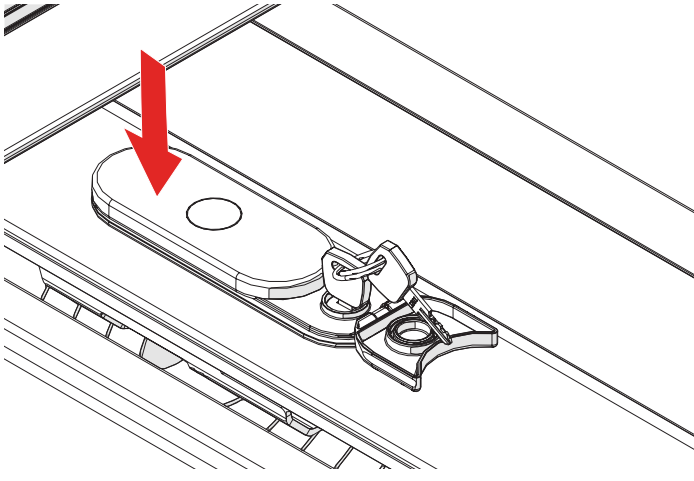

LOCK COVER ADJUSTMENT: A 3/32" Allen wrench can be used to adjust the pointed set-screw on the lock arm. Turn clockwise to increase latching pressure on the rail, or turn counter-clockwise if the lock is too hard to close. Use the same method on passenger side jam nut.

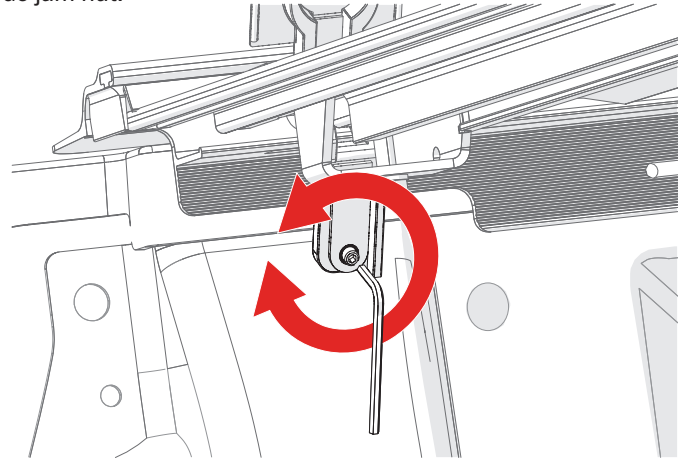

SECURING LOOSE CARGO: Retractable covers help in transporting loose and large cargo, a unique feature that most bed covers cannot claim. **NOTE:** Cargo should still be secured to the truck bed to prevent it from coming loose. To help secure any item too big to fit under the cover, latch the lock handle shut against the item to help keep it in place.

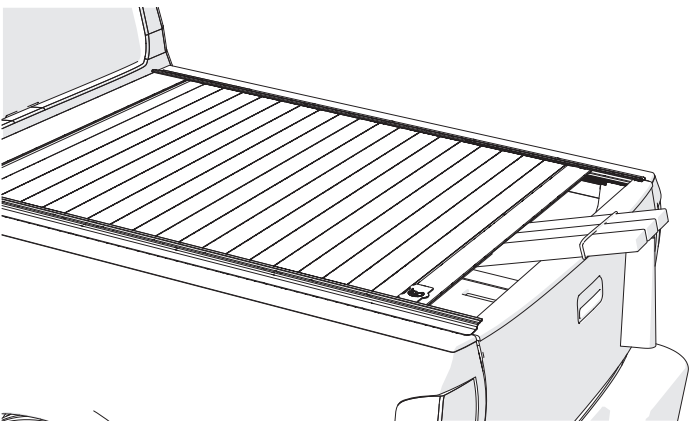

DRAIN TUBE REINSERTION WHEN REINSERTING THE COVER AFTER FIRST INSTALL: After the first install of the cover use the drain tubes coming from the canister into the top of the drain tube disconnect to reinstall and uninstall the canister from the fixed rails.

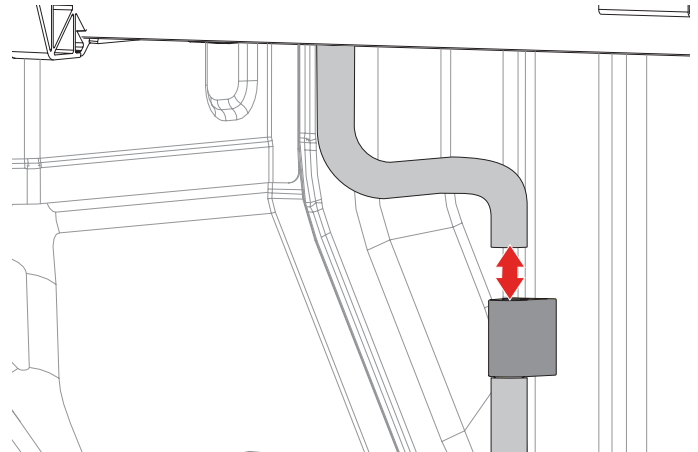

CARE AND MAINTENANCE

The truck bed cover requires occasional cleaning with mild automotive soap and water only. Avoid using abrasive cleaners as they may dull the finish. Some chemicals and fluids such as insect repellents, oils, solvents, and lubricants could potentially damage the rubber hinges and seals and void the warranty.

The weather stripping may absorb soapy residue from a car wash, it is recommended to wipe down the inside of the rails from time to time.

IMPORTANT: NEVER spray any lubricant or cleaner on the rails. THIS WILL VOID YOUR WARRANTY. The ball bearings are sealed and will not need any lubricant or spray. If the rails feel a little 'sticky', you may rub some paraffin (candle) wax along them until they wear in.

DO NOT wax your cover. The weather-stripping on your cover may absorb soapy residue from a car wash, so we recommend wiping down the inside of your rails from time to time.

CAUTION

Always read the ingredients of any product you are using to clean your truck bed cover. Make sure that you use only products that are safe for use with rubber. Many cleaners contain chemicals that could permanently discolor or damage your hinges and seals.

Periodically check that your cover is securely attached to your truck bed and working as intended. Inspect all hardware such as clamps and cover retainer clamps to ensure they are properly installed and working as intended. Covers that are used at high frequency or subject to rough roadways and/or heavy vibration conditions may cause the cover to require adjustment.

It is also recommended that you regularly inspect and service each panel latch. Clean away any excess dirt or grime. Ensure all latches move freely in and properly engage the side rail to provide optimal performance and security.

SAFETY INSTRUCTIONS

- DO NOT tow your vehicle from the rear with the cover on your vehicle. If towing from the rear is required, the cover MUST be removed from the vehicle and properly stored.
- DO NOT allow gasoline to come in contact with the cover.
- All large and heavy cargo must be secured by straps.
- NEVER allow children or pets in the truck bed while the cover is closed.
- The cover is not airtight. Special care is required to keep cargo clean and dry.
- Tonneau covers do not prevent theft of items stored in the truck bed.
- The draw latch pin must be inserted fully into the draw latch.
- Beware of pinch points when inserting the canister into the mounting bracket boot retainer.
- The draw latch bracket has an exposed rough edge.
- Use two people to lift the canister, following general lift safety practices: do not lift with your back, and avoid dropping it on your foot or other body parts.
- DO NOT use the lift handles as tie-downs. They are intended only for removing and inserting the canister into the truck bed, and for securing it to the rails.
- DO NOT use the lift handles to climb into the vehicle.
- Periodically check that all clamps are secure and tightened to the specified torque.
- Remove snow or any foreign material from the cover before operating it.

RACK SYSTEM INSTALLATION INFORMATION

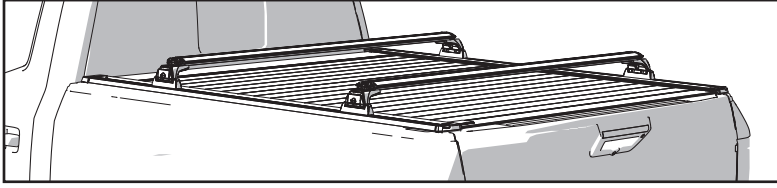

TRUCK OWNERS MANUAL

Be sure to refer to the truck owner's manual for load ratings for the truck. When calculating weight of cargo, be sure to include occupants and the cover. Cover with rack system= 125lbs.

RACK SYSTEM

For installation instructions and load ratings for the rack system, refer to the rack system's manual.

WARNING

Check the vehicle manufacturer's weight capacity in the owner's manual.

CAUTION

To prevent damage or loss of cargo when driving, check to make sure cross bars and cargo are securely fastened.

Loading cargo on the roof rack will make the vehicle's center of gravity higher.

Avoid high speeds, sudden starts, sharp turns, sudden braking or abrupt maneuvers; otherwise, it may result in a loss of control.

If driving for a long distance on rough roads, or at high speeds, occasionally stop the vehicle and make sure the cargo remains in its place.

Do not ever exceed the maximum vehicle capacity when loading the vehicle.

TROUBLESHOOTING

Canister getting stuck when you go to remove: Ensure that the canister is pushed towards the cab with the lift handle and disengaged from the mount bracket feature – push on the canister gently if needed to dislodge.

Draw latches not cinching all the way: Make sure canister is properly attached to the mount brackets. If needed, remove the canister and try to re-insert the canister install (see step 17). If this works, you can proceed with your use of the cover - if not, continue below.

Check that end caps are aligned properly, if not try one of the following:

1. Use the lift handles to adjust the canister left or right on the vehicle bed or
2. Check rail measurements (step 14 & 15) and make width adjustments to the rails attached to the bed if needed (step 16) be sure to secure the rails (step 13) once completed.

Flap seal not properly folded when installing the canister to the bed space: Slide/push the canister towards the cab of the truck and lift the canister up enough to position the flap seal over the bulkhead of the truck.

Draw latch arm is caught after inserting the canister: Remove the canister, move the draw latch arm back and reinsert the canister.

Drain tube disconnect becoming separated from the truck bed: Reconnect the hook and loop section attached to the bed with the back of the drain tube disconnect.

If there is an issue with difficulty using the pop-up latch:

1. Check the rail width measurements, see steps 14-16.
2. Adjust set screw if needed, see cover use section, LOCK COVER ADJUSTMENT

The serial number label is located under the cover next to the lock assembly on the tailgate extrusion. The serial number is 8 - 14 digits and may not include a letter in it.

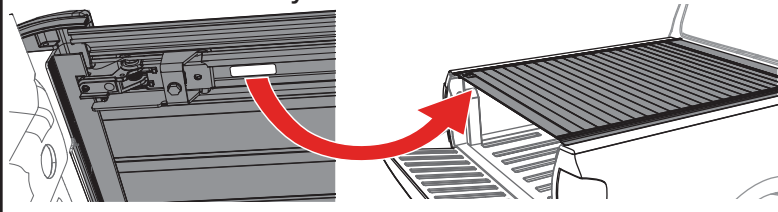

LIMITED WARRANTY

WARRANTY COVERAGE

This truck bed cover is warranted against defects in materials or workmanship as follows. This warranty is void if the product has been damaged in an accident, or due to neglect, unforeseeable use, improper installation, improper servicing, or other cause not arising out of defects in material or workmanship.

FRC-4000 - The truck bed covers carries a **limited lifetime** warranty from the original date of purchase, subject to the terms below.

WARRANTY IS NOT TRANSFERABLE

The warranty is to the initial consumer purchasing the truck bed cover and it is not transferable to a subsequent end user. Proof of purchase may be required to enforce these warranty rights.

WARRANTY CONDITIONS

Failure to follow these care and use instructions will void the warranty:

- Clean with mild automotive soap and water only. Do not use any strong chemicals or cleaners. Lubrication of the rails or sealed ball bearings will void the warranty.
- Cargo must be secured at all points when the vehicle is in motion. Failure to adequately secure the cover or tether strap can result in damage and will void the warranty.
- Check all clamps and retention mechanisms for tightness after a week of driving following installation (or re-installation) of the cover and periodically thereafter.
- Before opening, the cover must be free of all foreign materials including snow and ice.
- DO NOT tow your vehicle from the rear with the cover on your vehicle. If towing from the rear is required, the cover MUST be removed from the vehicle and properly stored.

WARRANTY PERFORMANCE

If all warranty conditions are met, a defective truck bed cover or hardware component will either be repaired or replaced (at our option). We reserve the right, for any warranty, to substitute a newer model or bed cover having a similar form and function, to offer a warranty discount on an entire replacement system, and/or provide remedies other than those mentioned in this document.

WARRANTY RETURN

A Return Material Authorization number must be obtained from our Customer Service Department prior to returning any product. We may require the original item to be returned postage prepaid for final determination. Shipping charges will apply for any repair or replacement. Other than postage or shipping charges, no charge will be made for repair or replacement under this warranty.

This warranty gives you specific legal rights. As a consumer, you may also have additional rights and remedies under the laws of your state.

<https://realtruck.com/warranty-registration>

**REGISTER
YOUR
WARRANTY
ONLINE**

